

MOUNTING RACETECH SEATS FOR NZ SPEEDWAY USE

It has come to our attention that some Racetechn seats fitted to speedway vehicles have been mounted with unsuitable seat mounts.

Unlike other forms of motorsport, Speedway New Zealand has very open rules when it comes to seat mounting and therefore there are many different designs and/or styles being used in speedway cars today.

The model of Racetechn seat you have purchased has been thoroughly tested overseas and, in many cases, meets and exceeds international FIA requirements. However, to ensure the seat can perform as intended, the seat mount design and manufacture must also exceed the intended load requirements of an impact. High speed and continuous high impact speedway racing is a unique form of motorsport and vehicles could experience forces above and beyond those that the seat has been tested to. Therefore, the use of Racetechn seats for contact speedway racing is totally at the driver's risk. To mitigate these risks, see below for the **minimum recommended standards** required to mount Racetechn seats into speedway vehicles.

Note: Some Racetechn seat models (RT4009HRV, RT4009WHRV, RT4229WTHR and the RT4229HRW manufactured prior to 2020) were manufactured with two threaded mounting bosses in the head beam. Mounting the head beam of these seats to your rollcage using these bosses is optional.

SEAT SIDE MOUNTING

Material: all side plates and must be a minimum of 3mm steel plate. Gussets must be a minimum of 6mm steel plate and at least 90mm high. All bolts used to mount the seat must be a minimum of M8, ISO 8.8 (as supplied with the seat).

Fitting: the side plate must be made as a folded 'L-shaped' section with a surface area contacting the seat shell (at both ends) no smaller than that depicted in the example profile supplied on Page 4. Side plates must be fully welded to the main structure of the chassis, or an equally sizeable support structural plate, at both front and rear of each side plate. Welding along the entire length of the side plate is preferred if possible. Each gusset must extend up to the height of the top bolt at each end of the side plate. The gussets can be on either the internal or external of the seat side mounts and there must be a total of two gussets per side mount.

OPTION 1

OPTION 2

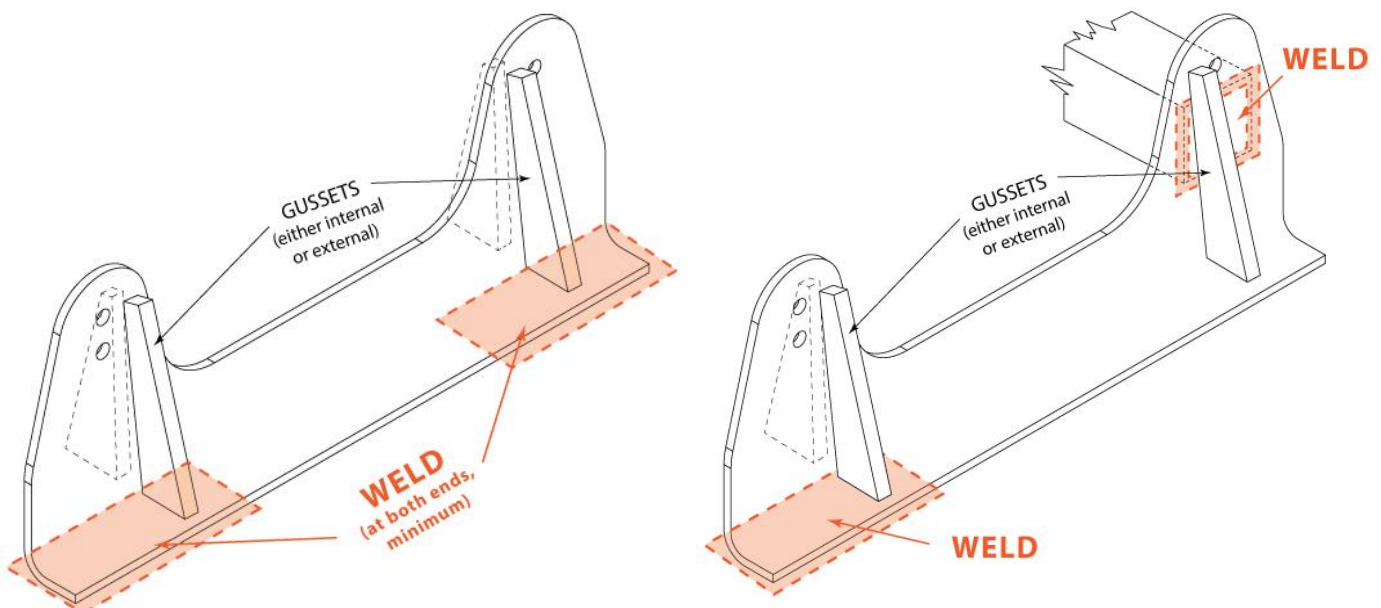

SHOULDER SUPPORT MOUNTING - OPTION 1

Material: must be a minimum of 50mm x 50mm, 6mm thick steel angle iron. The support must extend beyond the radius of the seat shoulder beam. For a standard width seat (HR/HRW), this is at least 400mm. For a wide seat (WHR/WTHR), this is at least 440mm. Bolts must be M8 minimum.

Top view

Fitting: the support must be fully welded to the rollcage cross bars (see example below).

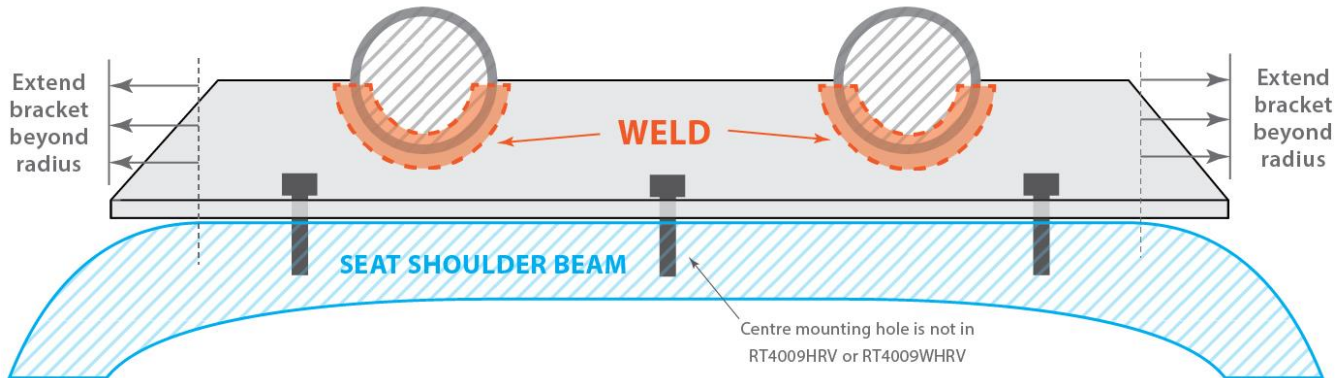

Rear view

Fitting: the shoulder support brace must be welded level to the shoulder support brace mounting holes. The mounting holes must be 25mm from the top of the 50mm angle iron (see example below).

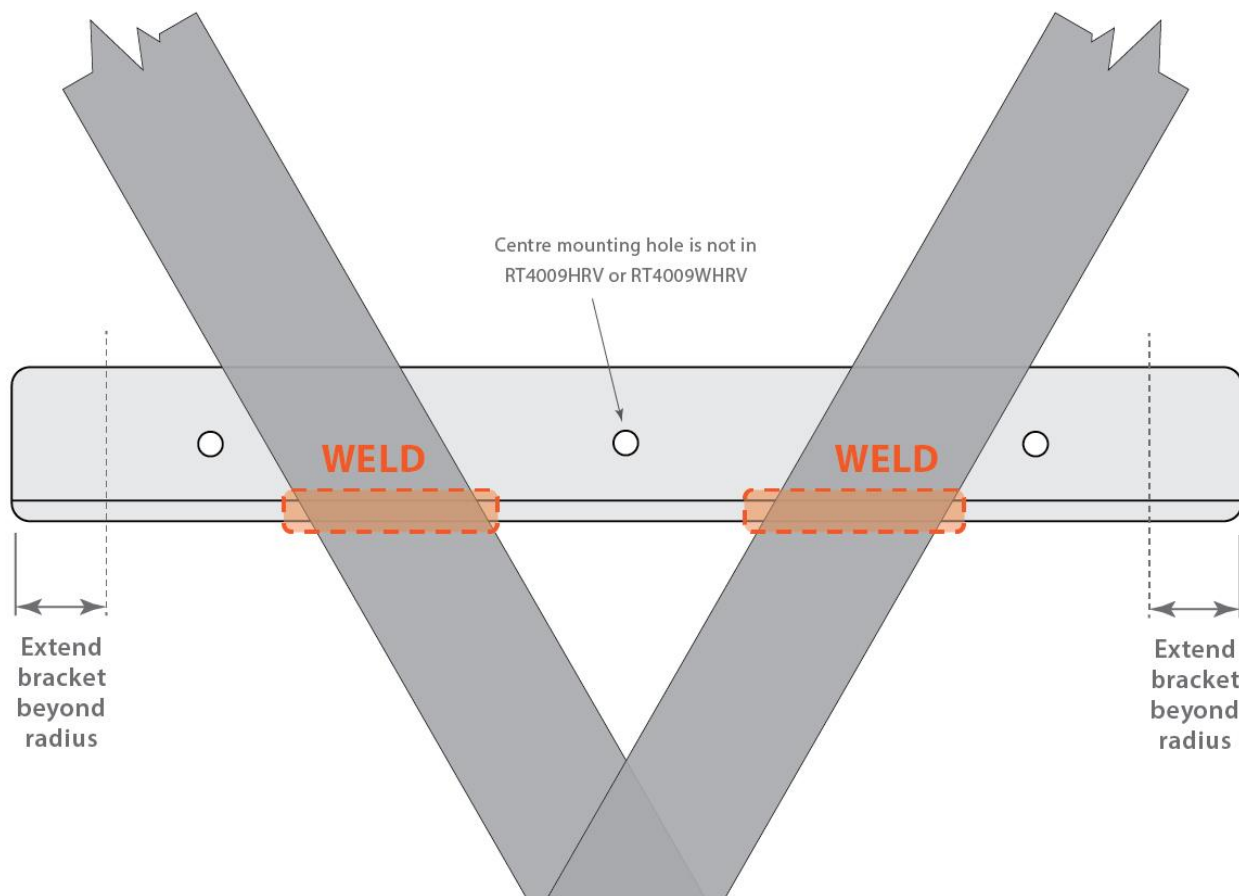

SHOULDER SUPPORT MOUNTING - OPTION 2

Material: must be a minimum of 50mm x 6mm steel. The support must extend beyond the radius of the seat shoulder beam. For a standard width seat (HR/HRW), this is at least 400mm. For a wide seat (WHR/WTHR), this is at least 440mm. Bolts must be M8 minimum.

Fitting: The support must be fully welded to the rollcage cross bars (see example below).

Side view

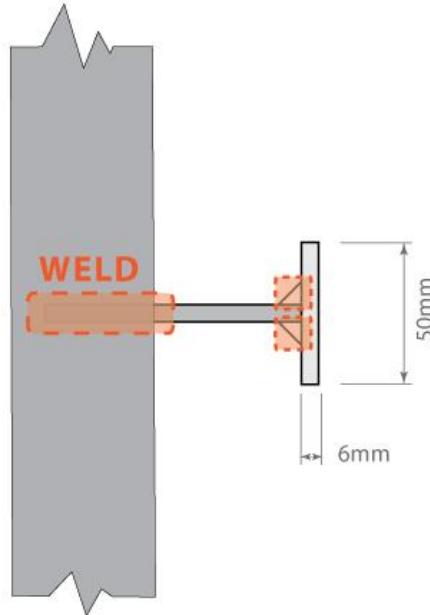

Rear view

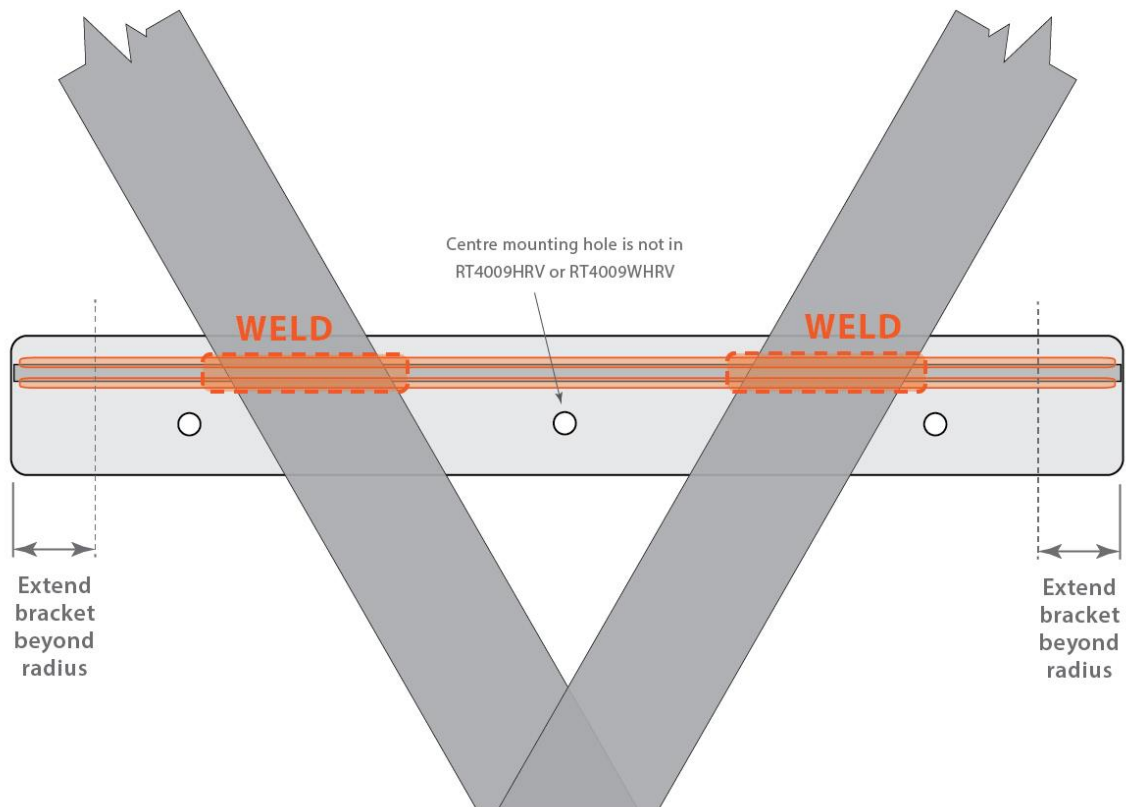

Side Mount Bracket Profile (example)

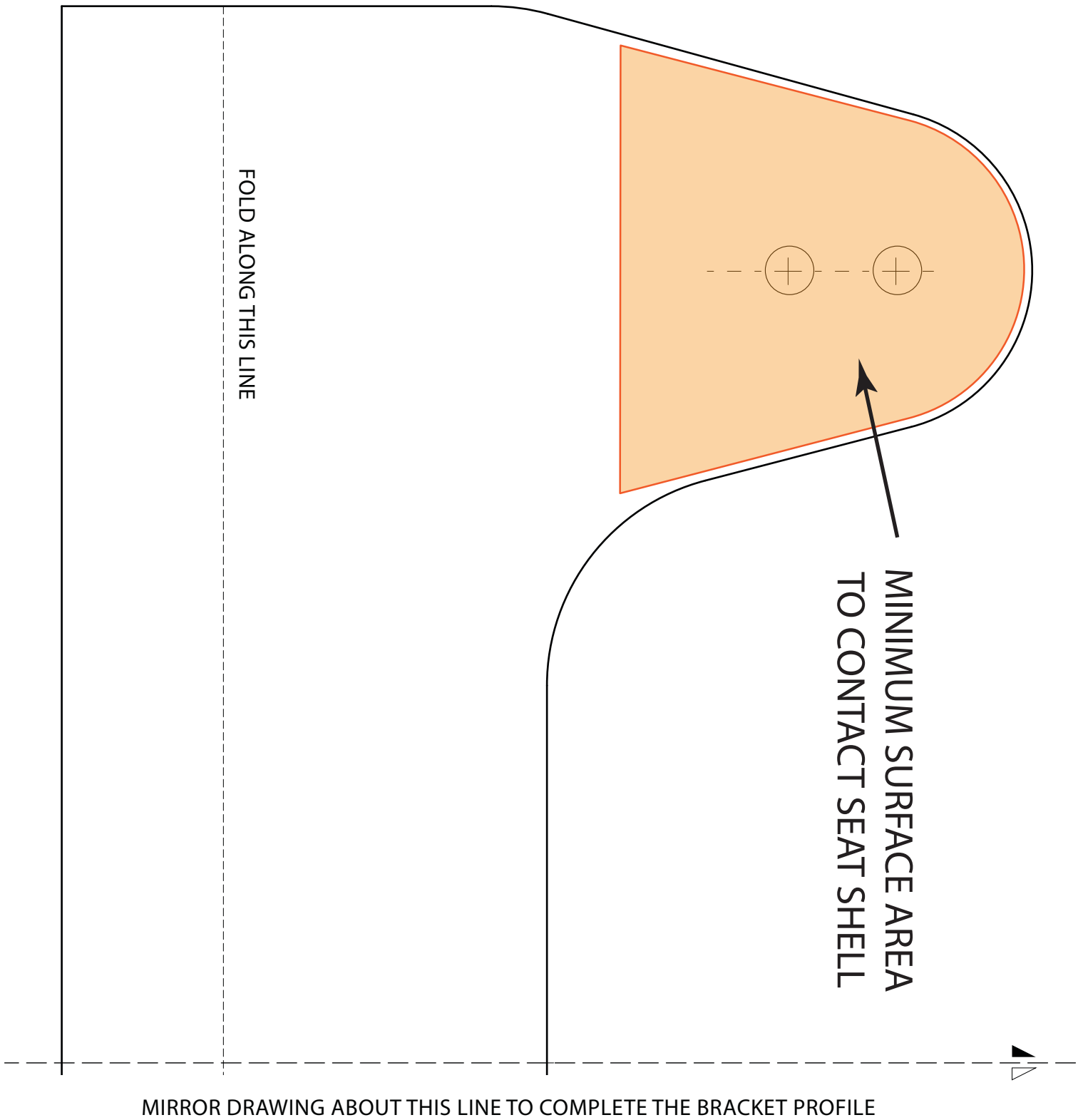

Notes

Drawing scale: 1:1 @ A4

Total bracket length: 392mm

Mounting hole spacing and fold line details are indicative only